

THE SOCIETY OF NAVAL ARCHITECTS AND MARINE ENGINEERS

601 Pavonia Avenue, Jersey City, NJ 07306

Tel. (201) 798-4800 Fax. (201) 798-4975

Paper presented at Fifth International Conference on Fast Sea Transportation, Fast'99

Bell Harbor International Conference Center

Seattle, Washington, USA 31 August - 2 September 1999

© Copyright 1999 The Society of Naval Architects and Marine Engineers

The Stepped Hull Hybrid Hydrofoil

Christopher D. Barry, Bryan Duffy

Planing hybrid hydrofoils or partially hydrofoil supported planing boats are hydrofoils that intentionally operate in what would be the takeoff condition for a normal hydrofoil. They offer a compromise of performance and cost that might be appropriate for ferry missions.

The stepped hybrid configuration has made appearances in the high speed boat scene as early as 1938. It is a solution to the problems of instability and inefficiency that has limited other type of hybrids. It can be configured to have good seakeeping as well, but the concept has not been used as widely as would be justified by its merits. The purpose of this paper is to reintroduce this concept to the marine community, particularly for small, fast ferries.

We have performed analytic studies, simple model experiments and manned experiments, and from them have determined some specific problems and issues for the practical implementation of this concept. This paper presents background information, discusses key concepts including resistance, stability, seakeeping, and propulsion and suggests solutions to what we believe are the problems that have limited the widespread acceptance of this concept.

Finally we propose a "strawman" design for a ferry in a particular service using this technology.

BACKGROUND

A hybrid hydrofoil is a vehicle combining the dynamic lift of hydrofoils with a significant amount of lift from some other source, generally either buoyancy or planing lift. There are also concepts that use aerodynamic lift, such as various types of hydrofoil windsurfers. There may even be concepts that use air cushions. The attraction of hybrid hydrofoils is the desire to meld the advantages of two technologies in an attempt to gain a synthesis that is better than either one alone, at least for a specific mission.

Buoyant hybrid hydrofoils generally have one or more torpedo-like submerged hulls or narrow catamaran hulls and derive reduced resistance through reduction of wavemaking drag and skin friction. Meyer (1992) presents a number of concepts merging buoyancy and hydrofoil lift, and an experimental Hydrofoil Small Waterplane Area Ship "HYSWAS" implementing this proposal was in operation on the Chesapeake in 1996. Smith (1963) described a high speed sailing craft that combines buoyancy and foil lift.

Partially hydrofoil supported planing hulls mix hydrofoil support and planing lift. The most obvious version of this concept is a planing hull with a hydrofoil more or less under the center of gravity. Karafiath (1974) studied this concept and ran model tests with a conventional patrol boat model and a hydrofoil, both of which were literally "off-the-shelf". His experiments showed drag reductions of up to 50%. His studies also revealed one of the most important problems of hybrid hydrofoils: many of his configurations were unstable in pitch. The subject of this paper is a particular configuration of partially hydrofoil supported planing hull that addresses the pitch instability issue.

The attraction of a partially supported planing hull is obvious: Hydrofoil lift is at least twice as efficient in terms of lift to drag as planing lift, but a hydrofoil needs a surface reference to maintain a controlled depth below water. By combining the two, the vehicle is much more efficient than an unsupported planing hull.

For example, arrange the vehicle so that about half the weight is supported by the foils, the other half

by the hull. The foils carry half the load but produce a quarter of the initial (planing) value. The reduced weight load on the remainder of the planing surface produces lower drag per unit lift because drag due to planing lift is proportional to load squared. Thus, the half load supported by planing is also carried more efficiently. The total comes to less than three quarters of the original value.

Hybrid hydrofoils have been a surprisingly fertile field of invention (though with perhaps an equally surprising lack of practical implementation). There is a specific subclass of patents just for hybrid hydrofoils with patents dating back to the early part of the century (Hayward, 1965). To our surprise (and disappointment when we got back a rejected patent application), Supermarin obtained a patent specifically on stepped hull hybrid hydrofoils in Sweden in 1951 following a 1943 application. The authors have also found hints in the literature that stepped hybrid hydrofoils actually saw service during World War II, though all of the craft we have been able to positively identify were probably full hydrofoils or hybrids with surface piercing foils forward and planing surfaces aft. Despite this heritage, hybrid hydrofoils haven't had a significant presence in the field of high speed boats. Interestingly enough, even the pure hydrofoil itself seems to be disappearing after a very promising start. Is this due to the traditional reluctance of the marine industry to embrace new concepts, some technical problem, or is the hybrid hydrofoil a solution looking for a problem?

The authors initially became involved with the hybrid concept when working on FMC's High Waterspeed Test Bed (HWSTB). The Marine Corps had determined that future amphibious assaults would have to be launched from over the horizon. This required armored amphibian vehicles capable of at least twenty five knots. It is the nature of armored vehicles to be very heavy for their size, so heavy that a planing hull is massively overloaded for the available surface of the bottom plate. This requires either extending the planing surfaces or somehow reducing the load. Duffty saw Karafiath's paper and convinced FMC that this was a solution. A hydrofoil provided an obvious means to reduce the planing load on the system so that the bottom plate could lift the remainder.

The progress of the High Waterspeed Test Bed project is beyond the scope of this paper, but suffice it to say that the concept worked and a half scale demonstrator representing a 66,000 pound armored vehicle made 35 knots true (not scale) speed. The authors decided to investigate application of some of their concepts to purely maritime boats, and FMC has

allowed them to use some of their work and concepts developed on HWSTB on their own.

This project has been limited by the time and funding constraints familiar to any garage inventor, (especially with one of us on each coast) but some progress has been made. This paper therefore represents a work in progress and is intended to reintroduce the stepped hybrid hydrofoil concept to the marine industry and to provide some inspiration to others.

We feel it also shows that some useful research can be done with funding limited to pocket change and scrounged equipment. Though we don't have a lot of good quantitative data, we have learned a lot.

PITCH INSTABILITY

Pitch instability is the chief issue in a hybrid hydrofoil. Planing hybrid hydrofoils can exhibit a dynamic pitch instability similar to porpoising, though the term describes this phenomenon even better than it does in a conventional planing hull.

This phenomenon can be best understood for a nominal configuration with a single hydrofoil beneath the center of gravity of a planing hull. If such a configuration is slightly disturbed bow up from an equilibrium position, the lift on both the foil and the hull will increase. The hull will begin to accelerate upwards and the intersection of the water surface and the keel will move aft. This develops a bow down moment, but at a relatively slow rate. By the time the bow drops enough to reduce eliminate the excess lift, the vessel is well above the equilibrium position, and the keel/waterline intersection is well aft. It falls back down toward the equilibrium position bow down, as if it had tripped on its stern. As a result of kinetic energy, it carries through the equilibrium position, takes a deep dive and springs up again. This cycle repeats, each time growing more severe. The motion resembles a porpoise even more than the similar motion in a planing boat, because the vehicle seems to jump through a series of invisible hoops, diving into the water after each one. The only way that this motion can be damped is if the hull provides enough damping to prevent the increasing overshoot. Note that this is a smooth water instability and occurs with only a nominal initial disturbance.

Even if the parameters of a vehicle are such as to provide sufficient damping to limit the growth of porpoising, the pitch/heave mode is still very weakly damped and therefore motions in head seas will be amplified in waves of the appropriate frequency.

Karafiath found that this instability in his experiments was correlated to the ratio of foil lift to total displacement and the ratio of foil lift moment to

weight moment (referred to the transom) and was a function of speed. Values of foil lift/hull lift exceeding 40% and foil moment to hull to hull moment of 50% was an approximate limit for stability. This corresponds to a foil under the center of gravity carrying half the vessel weight.

This limit is most unfortunate. It limits the effectiveness of the concept since the more weight carried on the foils, the more the drag reduction.

Other solutions include making the foil sense the surface and lose lift at a relatively low draft excursion from equilibrium. Some Soviet river hydrofoils were actually hybrids: They were carried by forward foils running close to the surface so that their lift was reduced by "biplane" effect. The stern was held up by planing so they were "tail draggers". A Japanese system (Kunitake, 1991) uses a forward surface piercing foil, and Rodriguez has run a foil assisted passenger ferry with an aft surface piercing foil.

A pair of foils forward and aft of the center of gravity can also be used. If the forward foil has a shallower rate of increase of lift with angle of attack than the aft one, the total foil center of gravity will move aft with pitch up and the distance of the foils from the CG will produce damping. This difference can be produced by reduced aspect ratio, so that the forward foil has a relatively small span and is long along the length of the boat. Unfortunately this means some of the lift is being produced by an inefficient foil. Such a craft is currently in service with the Thai navy.

Examining the static component of instability is illuminating: If the foil is forward of the CG, pitch up will result in increased foil angle of attack, more foil lift and more pitch up moment, producing still more pitch and more foil lift. If pitch up moment due to the foil exceeds pitch down moment due to the aftwards movement of the waterline/keel intersection (resulting in aftwards movement of the planing center of pressure) the vessel will pitch back until the foil senses the surface (or emerges) and loses lift.

The obvious solution is to move the foil aft so that increasing foil lift due to increased angle of attack from pitch up produces a bow down moment. Unfortunately, this results in reduced efficiency as well since the proportion of lift carried by each component is going to be distributed according to the relative distance from the center of foil and hull pressure and the center of gravity.

The hull will carry the lion's share of lift at its relatively low efficiency unless it is designed to ride relatively deep so that the planing lift center is well forward. The HWSTB designed by the authors in fact operated in just this condition and was stable. However, as noted above, the overriding feature of armored vehicles is that they are very heavy for their

length, (the displacement/length ration of the HWSTB was over 2,500) and no other marine vehicle would be so heavy.

STEPPED HULL

The stepped hull concept is obvious from this discussion. The foil is at the extreme stern of the vehicle and a step is provided forward of the CG. The step confines the planing lift to the forward part of the hull so that the relative position of the center of gravity, the step and the foil control the proportioning of lift between hull and foil. Bow up pitch of the vehicle produces a strong bow down moment, directly proportional to pitch, that reduces the pitch much more rapidly than the movement of the center of planing lift.

In addition, the pitch damping of a lifting surface is proportional to the square of distance from the center of pitch. The rotation in pitch in the bow up direction produces a downward motion of the foil if it is aft that adds to the forward motion vectorially. This downward motion is seen by the foil as a rotation of the relative flow downward so that the effective angle of attack of the foil increases even more than the bow up rotation. This increases the foil lift proportional to the rotation rate. The location of the foil well aft means that the moment is relatively large for a given lift due to the long moment arm. Over all, therefore, pitch damping increases with the square of distance of the foil aft of the CG.

The step also means that the running attitude of the planing hull can be set at a trim producing optimum lift. (This is one of the major advantages of a stepped planing hull also.)

ANALYTIC STUDIES

Calculation of Resistance

A first order computer model of a planing hybrid was made by combining the Savitsky (1964) equations and first order wing (lifting line) theory. For brevity, the details are not repeated here, but code for a similar program implementing this approach is presented by Karafiath.

The authors also developed some nomenclature and conventions that we feel are useful and are shown in Figure 1. The coordinate system is fixed to the vehicle with positive X forward and positive Y up with the origin at the transom/keel or step/keel intersection. The terms used in the figure are:

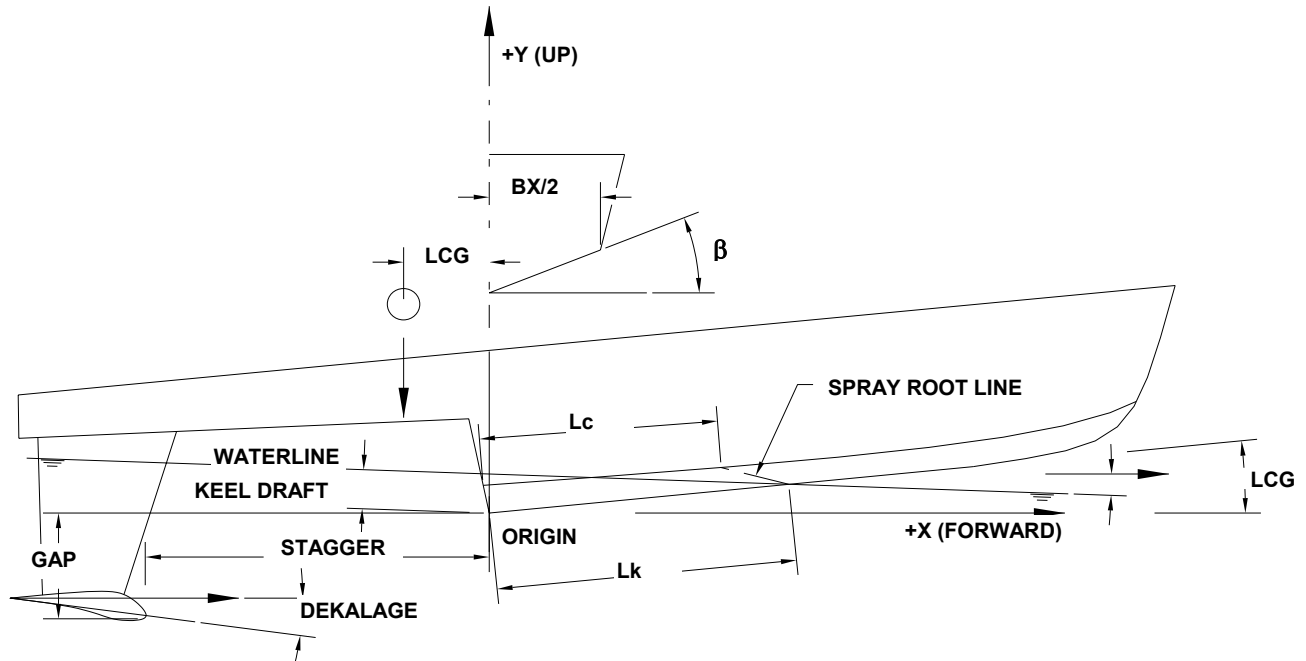

Figure 1 - Nomenclature and Axes System

BX	Planing beam, the effective beam of the each hull, generally the beam at transom.
β	The deadrise at the station chosen for effective beam.
Stagger	Location of the foil fore and aft, negative if aft of the step or transom.
Gap	Location of the foil below the transom, negative if below.
Dekalage	The angle of the nominal foil midline to the coordinate system. (These three term derives from terms used with biplanes.)
LCG	The longitudinal center of gravity, positive if forward of the step.
Lc	The length of the wetted chine, including wave rise.
Lk	The length of the wetted keel.
Drag	The angle of the keel with respect to the coordinate system. This angle could be taken as always zero by aligning it with the keel, because it is defined by foil position and dekalage as well, but geometry optimization is easier by letting this change.
τ	Trim of the coordinate system from the dynamic waterline, positive bow up.

Draft Draft of the origin below the dynamic waterline.

The trim and draft, and hence the wetted chine, keel lengths and foil angle and position will change such that the vehicle is in equilibrium, but must be initially assumed. The lift and drag forces and moments are then calculated and compared to weight and thrust. If the sum of forces and moments is non-zero, the trim and draft must be changed and the forces and moments are recalculated.

The program uses the Savitsky method as modified by Blount/Fox (1976) including their addition for hump drag. In this case, though we base the hump drag factor on the lift the planing surface is producing rather than the total vehicle weight. This addition is probably incorrect, but we felt it was the best option available. The hump condition is not well addressed by any simple approach. The wave making of the bow section will interfere with the foils and the aft section will be planing in the wake of the forward section until the foils lift it clear. Good model tests will be required to examine this condition.

Foil lift and drag can be calculated provided the limits of lifting line theory are met: The foil must have a large aspect ratio, be nearly elliptically loaded, be moving reasonably fast, reasonably well below a free surface and be of small dihedral and sweep. Since these limits also produce best performance any way, they are not important constraints for the model.

DuCane (1972) gives the equations that we used to calculate foil lift and drag under these assumptions and summarizes the derivation of these equations.

The effect of struts is to change the effective aspect ratio of the foil by partial blockage of the tip vortex much as the horns of newer airliners do. In some cases this effect is straight forward, in other cases it is very complex, and this represents the main challenge for calculation of performance for some configurations. DuCane gives equations for estimating some common cases. Tank tests or numeric flow methods must be used for other cases. An "ELL" foil with a strut is such a case. A foil with a strut of the same chord aligned with the foil with a typical motor pod was found by the authors experimentally to have an effective aspect of about 160% the geometric value. Since a foil against an infinite wall has an effective aspect ratio of twice the geometric one, this suggests that an aligned, full chord strut is 60% of an infinite wall, which seems plausible.

Though DuCane gives methods for calculating foil section drag, this is also found in the standard literature for specific foil sections and we use these values.

The effective angle of attack of the foil is the angle between the zero lift angle of the foil and the incoming flow. This angle is generally negative; the foil lifts with its nose down slightly.

DuCane also gives an approximation for spray drag and Hoerner (1958) gives values for interference effects.

Since many configurations of foils will require underwater housings for the propulsors or the control effectors, there will generally be one or more pods. The drag of the pods is estimated based on the standard literature with interference effects as required.

Minor terms such as aerodynamic effects, the moment due to thruster location and similar terms are added as required.

The result is a computer program that gives at least a first order approximation to the performance of a planing hybrid hydrofoil. The program was designed to allow the user to either select arbitrary draft and trim or to automatically find equilibrium. The former option allows investigating quasi-static stability terms, particularly of unstable configurations.

The program also allows any vessel parameter to be modified at each assumed step. The most important use of this feature is to modify dekalage, thereby simulating a rotatable foil. In order to allow finding equilibrium, the program has a factor that multiplies each iteration correction by a user set factors. This factor is a crude analogy of damping and inertial terms, and to a very limited extent, suggests the character of the vehicle's dynamic behavior: If each succeeding draft and trim derived by the misbalance of forces is multiplied by unity and the model still finds equilibrium quickly, the vehicle is more likely to be dynamically stable. If the factor is small and the model repeatedly goes off into numeric left field, the resulting vehicle may have dynamic stability problems. Though this is strictly an intuitive issue, in the FMC HWSTB, the authors found just such a correlation between computer simulation and tank tests.

Resistance Results

Resistance results are given in Figure 2 for a simple comparison case:

Length O.A.	20 Ft.
Weight	2,000 Lbs
60% CG	7 Ft.
(forward of the extreme aft end of the boat)	
Planing Beam	6 Ft.
Deadrise	15 Degrees

The hybrid version has its step eight feet forward the extreme aft end of the boat and is 40% quipped with a pair of two foot span by half foot chord foils at the extreme rear end one half foot below the baseline. The foil section is the General Aviation (Whitcomb) 1 section. The foil dekalage is set for several values.

20% Figure 2 shows that the reduction in drag between the planing hull and the hybrid can be very large. It also shows that the resistance is very dependent on the dekalage angle, suggests that variable dekalage may be required and that an incorrect dekalage actually increases drag.

Figure 3 shows the proportion of lift from the foil for each dekalage and speed. The resistance curves are plotted in the background to show the correlation between the percentage of foil lift and minima of drag. It is interesting to note that in this particular case, the minimum drag is not associated with maximum foil lift. Figure 4 suggests though that it seems to be more related to the condition when the foil percentage of drag is a maximum.

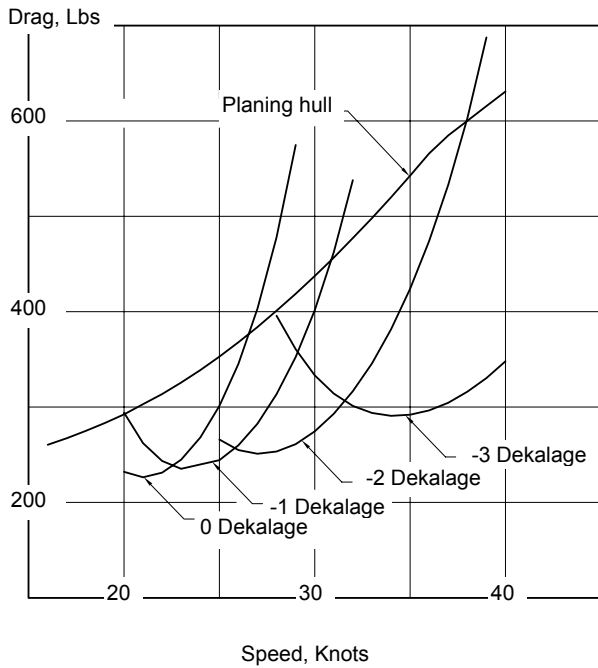

Figure 2 - Resistance Comparison

In fact this is a subtle clue. Though the configuration in question has reduced resistance compared to a planing craft, it is actually non-optimum.

The initial selection of parameters was such that it drove a local optimization away from the best condition, which would have more load supported by the foil, but this is not possible with the basic assumed parameters.

These figures serve as a warning. Exploring various designs with the model shows that it is quite easy to design a stepped hybrid hydrofoil with foils that are the wrong size, combined with a center of gravity in the wrong place so that the resistance is well above the comparable planing hull.

In fact, changing the foil from two "ell" foils totaling four feet of span to a single six foot span box foil produces a hybrid that has several times the drag of the equivalent planing hull for such a wide range of dekalages that no acceptable configuration was found.

There are many possible combinations of parameters with this concept, few of which work, so that use of a computer model is vital. Perhaps this is why the hybrid concept did not seem to catch on much earlier.

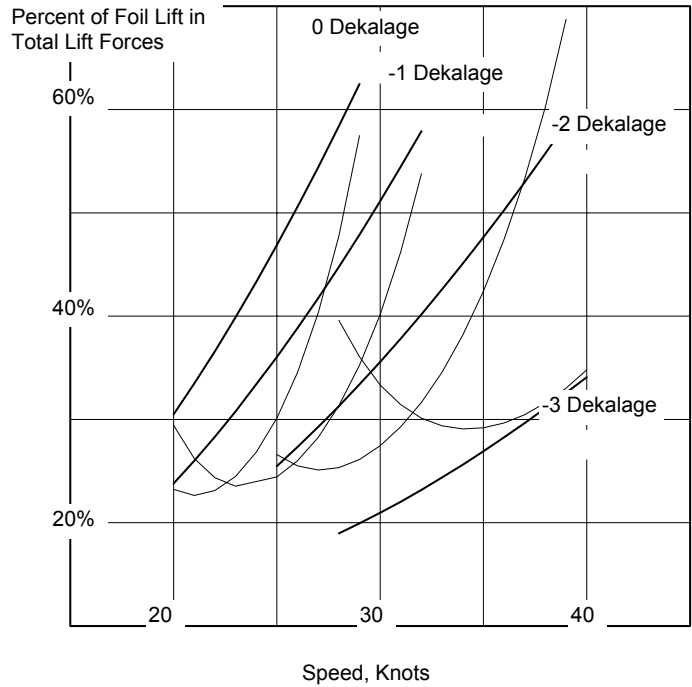

Figure 3 - Drag Minima Vs Foil Lift

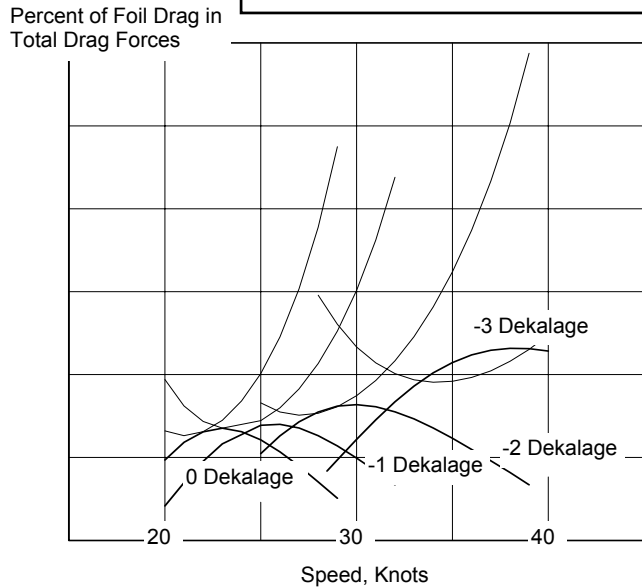

Figure 4 - Drag Minima Vs Lift

Foils

The use of the GA(W)-1 (McGhee & Beasley, 1973) in the example is worth discussing further. This section is one of a class of supercritical sections (also known as "barn roof" sections) that are designed by computer to achieve maximum lift coefficient with minimum possibility of stall.

The phrase "barn roof" refers to the fact that the section achieves uniform chordwise load distribution at the design lift coefficient, resulting in a lower peak pressure and a higher percentage of pressure forward and aft of the peak. This foil was used in the HWSTB for the same reason.

The pressure distribution curve is flatter than normal, and more filled in. As a result these sections are highly resistant to stalling. This is critical for some stepped hybrids as the lifted tail means that the vehicle may require extremely high lift coefficients in the takeoff mode. Cavitation is also reduced. The reduction of the peak pressure delays cavitation compared to NACA 65 series sections, at least at the relatively low speeds that hybrids operate. Such sections were not available at the time the stepped hull hybrid hydrofoil was initially developed and the problems of low speed lift may have contributed to the lack of popularity of the concept.

Dynamic Stability

Though it seems unlikely that a stepped hybrid will develop pitch dynamic instability, there has to be a definitive criteria.

Martin (1978a) and Payne (1974) have developed theoretical methods of determining stability for high speed planing boats. The methods are similar, though the authors happen to have used Martin's method as a basis. Extending these equations to the case of a hybrid hydrofoil merely requires adding the effect of the hydrofoil to the various terms of the equations. Again, in the interests of brevity, the only an overview of the method is presented

The pitch equation of motion has six terms. Three are the direct terms comprising pitch, pitch velocity and pitch acceleration times the spring-like terms due to planing lift changes due to trim; the damping terms; and the mass and mass-like terms respectively. The other three are the cross products producing moments from vertical position, velocity and acceleration.

The heave equation has a similar set of three terms producing vertical force due to vertical kinematics and three producing vertical force due to pitch kinematics.

The terms due to the hull determined stripwise integration of the sectional properties based on deadrise, chine beam and whether the particular section is fully immersed at the chines, wetted to the chines by spray or has dry chines.

The additional terms due to the foil are derived from ship control methods (Crane, et al, 1989). Since the rate of change of foil lift due to change in angle of attack ("lift slope") and the change of drag with respect to angle of attack are known from the resistance calculation, the important terms can be easily calculated.

The damping moment coefficient of the fin due to pitch velocity is the most important term and is directly proportional to the lift slope and the arm of the foil to the center of gravity squared. For any practical hybrid both of these will be large, thus producing very large pitch damping.

The other important terms in pitch are the moment due to pitch acceleration, and the moment due to pitch. Both increase with the arm squared and the moment due to increases with lift slope as well, so they are also very large.

The damping moments and forces in the heave direction are also substantial, because again, they are dominated by the efficiency of the foil, which we are trying to maximize for the sake of reduced resistance.

Other terms are quite small: Damping heave force due to heave is the change in lift due to depth which is negligible for a foil more than one chord below surface. The pitch forces and moments due to the foil rotating around its own center are likewise small. The heave forces on the foil due to heave acceleration are very small compared to the similar terms on the hull.

The actual form of each term will vary because it is customary to non-dimensionalize the terms into stability derivatives. The selection of the characteristic values used to non-dimensionalize will therefore change the expressions for the derivatives.

Once the various derivatives are known, the heave and pitch equations are combined and solved assuming the solution is a sum of exponentials. The result is a fourth order polynomial. Martin has assembled the various derivatives into the coefficients of the polynomial, so adding the foils merely requires adding the foil term to the appropriate hull terms and following Martin's procedure.

The resulting fourth order equation has four roots which can be real or complex. A complex root corresponds to an oscillatory motion, and if the real part is positive, the resulting motion grows exponentially, indicating dynamic instability. Since each root corresponds to a different mode of motion, all four have to be found and examined to ensure that there is no mode of motion that is unstable.

Such a set of equations has to be numerically solved, so no insight can be gained directly by examining an analytic solution. Instead, numerous systematic variations have to be examined. This task has been placed in our inbox.

Though we are still trying to get such a code working reliably, for any practical stepped hybrid configuration the method clearly results in very large values for those coefficients that characteristically produce stability; i.e. the damping terms.

Seakeeping

Many high speed craft are limited by motion in waves rather than power. Methods to analyze motions will be required to determine limiting conditions for crew and passengers, and structural loads.

Martin (1978b) has demonstrated how this proceeds for pure planing craft by extension of the stability method. This can be extended in a similar fashion by adding the foil terms for forces and moments from waves, but is worth noting that the foil excitation due to waves is relatively small because the foil is effected only by the orbital velocity of the waves and very slightly by the elevation of the foil beneath the waves. The velocities are small compared to the vehicle speed and the effect of elevation is minimal if the foil is in submerged below a chord length. The particle velocity effects and wave height effect also are opposed, so the net force is even smaller.

It is difficult to make general predictions about the seakeeping of stepped hybrid hydrofoils because this is even more profoundly affected by optimization but there are two important points that suggest good seakeeping is possible:

First, let's examine what has become the norm for planing and semi-planing craft designed for good motions in waves. A useful dry land analogy is the "chopper" motorcycle. The extended forks of the bike place the front wheel, which "senses" the road surface, well forward of the center of gravity and act as a soft spring connecting them to the rest of the bike.

Thus, the angle of pitch induced by the front wheel striking a bump is reduced because it moves the same distance up, but acts on a longer lever arm. The rate of acceleration of pitch is also reduced because the instantaneous force of the bump is reduced by the springiness of the forks. It acts through a longer time, though and thus achieves the necessary rotation for the bottom of the bike to avoid the bump.

Motions in head seas dominate the problem of seakeeping for fast craft, because at high speeds, all seas are head seas, so the analogy to riding on a bumpy road is very apt. Offshore racing craft, and "wave-piercing" catamarans both approach the problem of reducing motions in head seas in the same way, by moving the sensitive load as far aft as possible and by reducing the rate of lift force with respect to immersion of the forward sections, usually by making them narrow, with high deadrise.

However, if a planing hull strikes a wave, the force induced on the hull by the wave is primarily at the intersection of the hull and the instantaneous water surface. As the hull travels, this intersection moves aft, and the force becomes larger as the hull gets wider and deeper. The craft rotates more and more, and the rotation induced by the wave also tends to move the aft end down so that the disturbance increases.

In extreme cases, racing craft are sometimes thrown completely upside down, with the stern passing under the bow. This hasn't been seen in fast ferries, but some of the tendency to over rotate probably contributes to increased accelerations. In addition, once the wave passes under the hull, the pitch rotation changes and the craft can over rotate down into the next wave, increasing the following pitch up .

In contrast, a stepped hybrid hull will initially rotate, but the rotation will increase the angle of attack of the aft foils, which lifts the vehicle bodily upwards from the rear and reduces pitch acceleration. The hull is therefore "anticipating" the oncoming wave and goes over it like a horse clearing a hedge. This motion has to be carefully tuned to the anticipated wave environment for optimum performance, but it is clear that a properly designed stepped hybrid hydrofoil could have excellent motions.

Second, with the wide range of parameters available to the designer, it is clear that there is considerable latitude to optimize for motions. A hull form with very high deadrise, low freeboard planing hulls forward and foil support aft could be developed with very good motions because the foil would bear the majority of the load and the hulls could be relatively inefficient, hence relatively soft riding. In a pure planing hull, the designer has to lose efficiency by accepting a high deadrise, soft riding hull. The cost of non-optimum lift production for the sake of seakeeping would be much less for a hybrid hydrofoil.

Propulsion

A problem of hydrofoils that hybrids share to a significant measure is that of propulsion: Getting the force into the water often requires passing it through the struts which is costly in terms of money, appendage drag, complexity and efficiency. Hydrofoils use mechanical, electric and hydraulic drives to props on foil pods, jets taking suction through the foil, and shafts from the hull.

Each of these methods has problems. Jets taking suction through the strut add strut drag and cause loss of velocity head. Hydraulic and electric drives add cost and efficiency losses. Mechanical drives have lower efficiency losses, but are complex and costly and have large, highly loaded bevel gears in large, drag-producing pods. All types of pod mounted propulsors produce drag due to the frontal area of the submerged drive components.

The possibility that variable dekalage may be required on a hybrid adds another problem to configurations with props on pods and mechanical transmissions. The most obvious way to produce variable dekalage, especially if the foils need to be retracted, is to rotate the foil and strut assembly around its connection to the hull. Transmitting power through such a variable angle joint is possible but adds additional complexity not present in a hydrofoil strut that is mechanically connected in only one position.

There is some consolation that the struts of a hybrid are somewhat shorter, but this is only important for through-strut jet drives, and jet drives require higher flow rates for efficiency at the lower speeds of a hybrid.

However, unlike a pure hydrofoil, a hybrid can be propelled by hull mounted components. A jet drive could be mounted in the forward planing hull and discharge at the step. A prop shaft could penetrate through the step as well or surface piercing props could be mounted on or below the raised tail and dip down to the water. This gives some added versatility to the hybrid concept that a pure hydrofoil doesn't have.

The choice of propulsion method is economic and operational and will be determined by the mission. The hybrid offers wider latitude for less costly methods than a pure hydrofoil, but requires an innovative approach to the issue.

EXPERIMENTS

Thomas Edison performed over a thousand experiments in the course of inventing the electric light. Most were failures in the sense that they did not produce a working light, but Edison regarded them as successes in that he learned from each of them. We have taken solace in this, because our most ambitious experiments also failed to produce working craft, but we learned a great deal and feel we now understand much more about the practical problems of stepped hybrid hydrofoils.

Small Models

Mr. Kenneth Foster, formerly CEO of Munson Manufacturing, met the authors and became interested in this concept, and as a sanity check purchased two identical radio remote controlled model boat kits. He modified one to a stepped hybrid hydrofoil configuration and ran the two side by side. He found the hybrid configuration was often substantially faster than the unmodified one though the placement of weight, size and angle of the foil and other parameters made substantial differences. Some configurations were in fact much slower. He never noted any pitch or roll instability and discovered that getting the hybrid to turn was a substantial problem, as his model had no ailerons, only rudders.

This experiment was not well controlled and is subject to many objections, however, it showed that there is something to the claim that a stepped hybrid can be faster than a comparable planing hull for similar power, can be stable in pitch and roll, and is strongly dependent on the details of configuration, particularly foil angle.

Since then the authors have built a number of small self-propelled models and found much the same thing. There were numerous cases of hybrids being twice as fast as similar pure planing craft, but the hybrid definitely could be slower if improperly optimized.

One phenomena we ignored until later also proved to be an important hint. The small models propelled with model airplane motors announced that they had come onto plane by a sudden change in tone from a growl to a high whine.

Manned Model

One of the authors (Duffy) built an eight foot plywood stepped hull, modified from plans for a skiff. The hull was fitted with a box foil made from aluminum by taking plane cuts with a milling machine and hand finishing.

The model was built prior to completion of the resistance program and thus not optimized. The foil section is flat bottomed similar to a "Clark Y", but actually not a specific tabulated section, due to limits of the manufacturing process. It has provision for changing the foil angle and vertical and horizontal location. It was intended to be powered by a small outboard motor or to be towed and is provided with buoyancy and other safety features to be manned.

The initial test was run in San Francisco Bay off Berkeley. The weight of the motor and driver resulted in an aft static freeboard of less than two inches and the vehicle swamped during takeoff. Additional foam flotation was added but the vehicle failed to get over hump.

The outboard was not able to produce full power, partly as a result of being swamped and partly due to being in excess of thirty years old. However, there was a key propulsion problem which might also occur in full size craft: The propeller was suited for high speed and had so much pitch that it would not allow the engine to achieve full RPM, and hence it did not have the power required for coming up on hump, even if the engine had the necessary power at full RPM. This was the warning of the small experiments: The hump condition is critical for hybrid hydrofoils and some radical provisions may be required to allow engine matching in both the hump condition and the running condition.

To alleviate the problem of motor performance the boat was towed. Finally, while coming up to hump, the vessel rose, began to fly, but took a sudden roll to starboard, dipping the bow. Additional outboard foils were added with dihedral to gain roll stability. Again it failed to go over hump, but seemed to be trying to bury the bow.

After the last experiment, the resistance program was complete and the model performance is being studied with the program. Further experiments are being planned.

The problem of burying the bow is of some concern, especially considering the sudden roll to starboard: It is known that weight too far forward on a planing surface can cause the rounded portions of the forward buttocks to enter the water and cause roll instability (Codega and Lewis, 1987, Cohen and Blount, 1986).

This is because the flow around the curve causes suction. The skiff used was, of course, designed to be eight feet long and run by an operator in the stern. The forward buttock lines are thus quite rounded and could create a condition which might be the source of the roll instability and the failure to come over hump.

This phenomena may present special issues in the design of the planing portions of stepped hybrid hulls.

Human Powered Vehicle

Though not intended as an experiment per se, when both authors were at FMC, they made a proposal that FMC explore the commercial viability of the hybrid as an alternative product line.

Since FMC had marketed commercial hydrofoils in the early 60's this was received with some interest. A demonstration was conceived that would definitively show the concept, its niche as an intermediate speed vehicle and incidentally provide a corporate recruiting publicity video. FMC therefore granted limited funding (materials and use of company facilities) for a volunteer attempt at the DuPont prize for the first human powered vehicle to achieve twenty knots. At that time, FMC employed a member of the US Olympic sprint cycling team as a mechanical engineer, and had a substantial advanced technology base in ultra high strength low weight composites, so this project seemed ideal.

The hybrid concept is suited to speed ranges somewhat lower than pure hydrofoils. Brooks, Abbott and Wilson (1986) note that an ideal human powered hydrofoil has too high a takeoff power at too high a speed to be practical. The hybrid concept is better suited to the speed ranges required for the DuPont prize. The vehicle was never completed but the design process and limited experiments also taught lessons.

First, the optimum vehicle obviously had very low hull loading. This, in turn, resulted in a very narrow planing surface on the forward hull. In retrospect, this would probably have resulted in a roll stability problem at speed, because the stabilizing moment of foil dihedral is related to the cosine of the dihedral angle and is thus very small for acceptable ranges of dihedral. This in turn suggests that monohull stepped hybrid hydrofoils may not be optimum for resistance.

Second, the pods were a major source of drag, as much as the induced drag of the foils. Bevel gears to transmit the power levels required had a diameter in excess of an inch, even at a lifetime of a few minutes, resulting in a pod on more than three inches in diameter. This reemphasized the problem of propulsion.

In the middle of the project, the Soviet Union began to collapse and the need for new armored vehicles, and hence corporate recruiting, reduced. Worse, the critical component, the "engine", found a better job with another firm, so the project ended without hitting the water.

The participants are still in contact and have many components left over from the project and hope one day to reassemble and try again.

Future Testing

Clearly, model tests capable of measuring resistance, speed and motions with some accuracy are required.

- The resistance program methods must be checked and validated.
- A deliberately unstable model should be run to validate the dynamic stability analysis.
- The issue of bow curvature could be explored.
- There is a possibility that the spray from the planing hull will impinge on the raised aft portion and cause drag not accounted for in the simple theory.
- Use of the Blount/Fox hump drag factor could be checked and the hump region performance can be examined.
- Measuring trim angle and varying foil and hull parameters would allow exploring the effect of the hull flow on the foil.
- The effect of alternative planing hull forms not covered by the Savitsky equations can be explored.
- Wakes produced by hybrids can be compared to comparable planing hulls.

LESSONS LEARNED

Our experiences suggest the following points for the design of future stepped hull hybrid hydrofoils:

- A monohull hull form is probably inappropriate for a combination of optimum efficiency and adequate stability.
- High lift foil sections are probably required.
- Propulsion matching is an important problem.
- Optimization is a considerably more difficult problem than it first appears and is critical.
- Hull form design has subtleties we don't fully understand.

However, we should also tabulate the practical problems and advantages of the stepped hull hydrofoil:

- The struts are a potential problem for collisions with debris, though they are somewhat shielded by the forward hull and shorter than those of a hydrofoil.
- The strut connections are heavily loaded, though not as much as the forward strut of a hydrofoil.
- Severe waves will load the hull more than a hydrofoil (though this reduces the load on the struts).
- Propulsion will always be more complex than a planing hull because of the hump power problem and the need to transmit power to the water below the hull.
- When waterborne at slow speed, the hull will either be severely trimmed bow up or require ballast or movement of weight forward.
- Motions are reduced compared to a planing boat, but they will never be as good as a hydrofoil with automatic controls.
- The running draft at speed is more than a planing boat.
- The concept is inherently a single speed one. Performance at other than top speeds will be poor.
- The foil is not a common component and will be costly unless methods for low cost foil manufacture can be developed.

STEPPED HYBRID HYDROFOIL FERRIES

A high speed ferry is an obvious mission for a stepped hybrid hydrofoil. A ferry is a two speed vehicle, and the hybrid concept is well suited for this.

Most practical new ferry routes in the US require a speed on the order of thirty to forty knots to compete with automobiles provided the speed can be achieved at an acceptable level of cost and reliability. This appears to be the optimum range for this concept, so a stepped hybrid may be able to achieve a lower cost and better reliability at these speeds than hydrofoils, SES's, or planing boats.

The stepped hybrid concept is much less dependent on size for speed and seakeeping than a conventional planing hull, so smaller, less expensive ferries are feasible. This allows either more ferries on a given run or use of ferries for runs with much less traffic.

A number of high speed ferries are limited by wake damage to the shore. As a result, they can only run at speed for a small portion of the route. A hybrid should produce substantially less wake than a planing monohull or even an SES because the foils generate substantially smaller waves. Whether this would be enough reduction is a second question, but the comparison of wakes should be a goal of future model test programs.

Proposed Design

The authors envision a 80 passenger ferry that would have a pair of narrow hulls well forward terminating near midship with a central hull aft, raised above the catamaran hulls. (Figure 5)

The configuration would be reminiscent of a "picklefork" three point hydroplane, but the aft point would be a "U" foil running under the aft end of the center hull. The foil would be pivoted at the top end for dekalage adjustment and could be provided with an upper ladder foil that would be dry at full speed, but help in takeoff. The aft end of the cross deck would be immersed at low speeds to minimize bow up trim and provide additional lift to get over hump and would be fitted with a wedge or flap to increase planing lift in takeoff mode.

The craft would be propelled by surface piercing drives or waterjets mounted in the transoms of the forward hulls. Since waterjets do not tend to overload the engine at low boat speed and the jet suction would always be immersed in this position. Waterjets are also well suited to the 30 -40 knot speed range. Surface piercing props are also an attractive alternative. The use of surface piercing propellers would require some means to address the problem of overloading the engines at hump, but ZF has recently placed a range of two speed gearsets on the market to address similar problems for planing monohulls. If the power required to take off is excessive, an aft engine could be provided on the center hull.

An other alternative is to use a high speed composite flywheel for storing power. The engines would spin up the flywheel through high ratio gears and fluid torque converters or electric couplings during the pre-takeoff run, then use the stored power for the few moments of high demand.

Foils for such a craft would be less expensive than for a conventional hydrofoil. High strength stainless steel is the normal material for fully flying hydrofoils, to resist cavitation, to provide adequate strength and to resist corrosion, but it is expensive, both for materials and to fabricate. For example, the HWSTB had a pair of aluminum foils only a few feet long, but each required over twenty-four hours on a very large CNC mill to produce.

The lower speed of a hybrid means that cavitation is not such a problem and that the foils will be larger and hence have greater section thickness than a normal hydrofoil. The high lift sections also have relatively thick sections as well.

Our studies indicate that adequate foils could be made by casting plastic materials over a welded steel core. Polyurethane with a Shore hardness in the 80-90 range cast over stainless steel cores has been used for rudders of planing craft. This material might be familiar to some of us as it used for roller blade wheels. It also has also been used in tape and painted on form as a protective barrier to resist cavitation and abrasion in slurry service. It is relatively inexpensive and can be cast in simple molds at room temperature, so that heat treated steels can be used if required for strength.

Banking control would be achieved by blowing air over the top of the foil through tubes cast into it, thereby eliminating the need for expensive control surface actuators and the drag on their housings below the surface.

Such a craft would be about 75,000 lb. full load and require only about 675 EHP to achieve 35 knots, so a pair of diesel engines in the 700 BHP range would be sufficient. Such comparison are always suspect, but about 2000 BHP (total) would be required to propel a conventional monohull planing craft of the same weight to the same speed. A catamaran of the same weight with two 700 BHP engines would only be able to achieve 26 - 27 knots.

The main merit of a hybrid solution for this type of craft is in the relatively small size (and cost) for such high speeds with acceptable seakeeping as discussed above. This makes it uniquely suited for urban service in competition with overcrowded freeways.

We intend this craft specifically for the San Francisco Bay Area to serve a multipoint commute route, with loops connecting San Francisco with the northern East Bay (Berkeley), the mid Peninsula (Redwood City) and the mid-southern East Bay (Hayward) and other loops connecting Marin County, Vallejo, San Francisco, and Richmond.

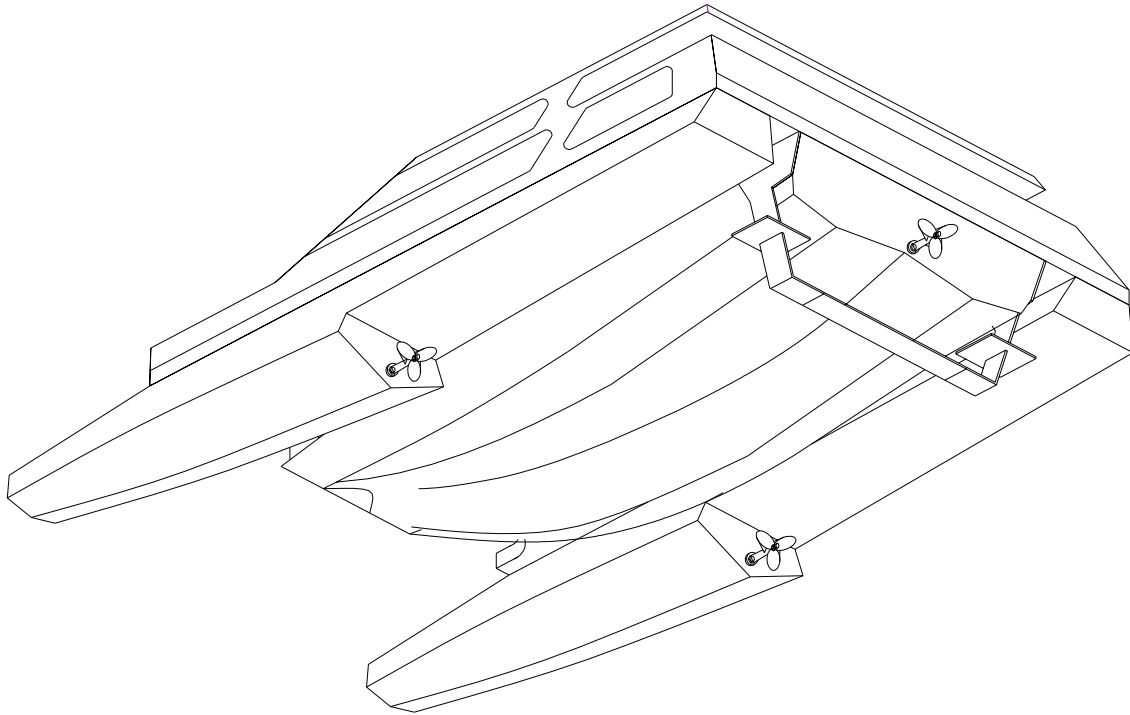

Figure 5 - Small Ferry

The small size of the ferries would allow them to enter recreational marinas and travel into shallower water at high speed. The low cost would allow many ferries on a route so that the delay between ferries would be small thus reducing the probable trip time (which includes some probability of missing a ferry).

The small passenger load would also interface well to city buses or shuttles. There is no point in getting off a 600 passenger ferry and waiting in a traffic jam of ten buses and twenty shuttles in the parking lot.

Short runs in crowded areas like San Francisco also involve a relatively high proportion of time at low speed. Our studies indicate that the overall trip time saved for typical voyages is only a few percent for speed increases above about 35 knots, though trips at speeds below 30 knots are substantially increased by top speed reduction.

Another advantage of a relatively small craft for areas like the Bay Area arises from the current trend toward dispersion of jobs and housing. The growth of "second generation" businesses in the suburbs (founded by employees of first generation businesses who got tired of commuting) has made the commute pattern completely disorganized. The classic "New York" model of workers commuting from all over into one point is almost dead in many areas, because as people change jobs to work for these firms, they don't move, they just commute in different directions.

This is occurring in many other areas. In the Chesapeake, firms are beginning to locate on the Eastern Shore, so a counter commute eastward has begun. One of the authors had just such a commute history, living in San Francisco and working for a while in Marin County, then in San Jose, commuting against the classic flow. Small ferries can add flexibility to the commute pattern, because transfers no longer involve long waits, and one or two peculiar flows can be accommodated by one or two runs each way per day.

Perhaps the most important advantage of small size, however, is the possibility of "growing" a service. A conventional planing hull or catamaran must generally carry several hundred passengers to be large enough to achieve acceptable speed and seakeeping. This means that the operator has to have some notion that there are a thousand or more passengers per day to be able to run a system economically, and those passengers have to appear in time to reverse the operator's cash flow before he runs out of money. A small, fast, inexpensive ferry allows the service to be built up, changing commuter's habit gradually. This also means that small enterprises can start these ferry lines to serve a specific route, such as one out of a new real estate development. These services could also be community owned enterprises.

A stepped hull hybrid might be competitive in other services, but as the optimum craft gets larger, the speed and seakeeping advantages of the hybrid becomes less significant, and the difficulty of fabricating large foils begins to be a concern.

We believe that the small "mosquito boat" type service we envision might be an optimum role for this concept, and the stepped hull hybrid, in turn, is the optimum concept for such a service.

FURTHER DEVELOPMENT

This paper is definitely a report of work in progress. Much further development is required to determine if this technology has merit and in what cases.

- Resistance calculation methods have to be verified and extended to the hump speed regime.
- General guidance for optimization has to be developed.
- Stability and seakeeping analysis techniques have to be developed and verified.
- Structural criteria have to be developed, particularly for foil fatigue loading. This in turn requires seakeeping analysis techniques, and probably cooperation of one of the classification authorities.
- Strawman ferry designs for various services have to be done and evaluated.
- Methods to produce foils at low cost have to be proven.

CONCLUSIONS

The stepped hybrid hydrofoil is presently a little known historic curiosity. It has merits in reduced resistance compared to planing hulls at lower complexity than pure hydrofoils. It may have merits in seakeeping and other operational areas. Its current status may be due to being eclipsed by the pure hydrofoil, but it should not be viewed as a partial step to the hydrofoil. It is a valid concept on its own with its own special characteristics and capabilities.

The authors have presented some of the issues, proposed methods to analyze critical areas of performance, and shown concepts to address key areas of concern in design.

Stepped hull hybrid hydrofoils especially merit consideration for high speed ferry service for partially sheltered runs where seakeeping is a consideration but not an overriding one, where there are factors limiting size on a given run, such as traffic dispersion and where moderately high speeds are required.

We suggest that San Francisco Bay presents just such an opportunity, and there are probably other services with similar characteristics worldwide.

ACKNOWLEDGMENTS

The authors would like to acknowledge FMC Corporation for their support and generosity, the members of the FMC Human Powered Vehicle project, especially George Thomas and Bruce Wade for their expertise in composite structures.

They would like to thank the members of the Cal Sailing Club for support in the manned prototype testing, especially Paul Kamen, who has contributed much technical insight as well. They would also like to thank Kenneth Foster for his interest and for building and testing the radio remote controlled models. Michelle Barry deserves credit for preparing some of the figures.

The views and opinions expressed herein are those of the authors and are not to be construed as official policy or reflecting the views of the U. S. Coast Guard or the Department of Transportation.

REFERENCES

- Blount, D.L. and Fox, D.L.** "Small Craft Power Predictions", *Marine Technology*, January, 1976, Society of Naval Architects and Marine Engineers
- Blount, D. and Codega, L.** "Dynamic Stability of Planing Boats", *Marine Technology*, January, 1992, Society of Naval Architects and Marine Engineers
- Brooks, A. N., Abbott, A. V., and Wilson, D. G.** "Human Powered Watercraft", *Scientific American*, December, 1986
- Cohen, S. and Blount, D.** "Research Plan for the Investigation of Dynamic Instability of Small High-Speed Craft", *Transactions of the Society of Naval Architects and Marine Engineers*, 1986

- Crane, C. L., Eda, H., and Landsburg, A.,** "Controllability", Chapter IX, *Principles of Naval Architecture*, 1989, Society of Naval Architects and Marine Engineers
- DuCane, CDR P. M.,** *High Speed Craft*, 1974, David and Charles Ltd., Devon
- Hayward, L.,** "The History of Hydrofoils", *Hovering Craft and Hydrofoils*, July 1965
- Hoerner, S. F.,** *Fluid Dynamic Drag*, 1958, (Published by the Author)
- Karafiath, G.,** *An Investigation Into The Performance of NSRDC Model 5184 Configured as a Partial Hydrofoil Supported Planing Craft and a Comparison with a Powering Prediction Technique Report SPD-585-01*, December, 1974, NSRDC
- Kunitake, Y., Nojiri, T., Kurihara, K.** "Planing Boat", U.S. Patent 5,002,004, March 1991
- McGhee, R. J., and Beasley, W. D.,** *Low-Speed Aerodynamic Characteristics of a 17-Percent-Thick Airfoil Section Designed for General Aviation Applications*, TN D-7428, NASA, December, 1973
- Martin, M.,** "Theoretical Determination of Porpoising Instability of High-Speed Planing Boats", *Journal of Ship Research*, March, 1978, Society of Naval Architects and Marine Engineers
- Martin, M.,** "Theoretical Prediction of Motions of High-Speed Planing Boats in Waves", *Journal of Ship Research*, September, 1978, Society of Naval Architects and Marine Engineers
- Meyer, J. R.,** "Hybrid Hydrofoil Technology Applications", *HPMV '92*, June, 1992, *American Society of Naval Engineers*
- Payne, P.,** "Coupled Pitch and Heave Porpoising Instability in Hydrodynamic Planing", *Journal of Hydronautics*, April, 1974
- Savitsky, D.,** "Hydrodynamic Design of Planing Boats", *Marine Technology*, October, 1964, Society of Naval Architects and Marine Engineers
- Smith, B.,** *The 40-Knot Sailboat*, 1963, Grosset & Dunlap, NY